

**Sturdy Aluminum Backbone**

Adapts safely to your mounting requirements—no external strengthening members required. Robust steel mounting clips easily adjust to meet actual field conditions.

**Trouble-free Head Block**

Nylatron sheaves offer proven reliability for long, trouble-free life. Sheave and drum diameters meet or exceed wire rope manufacturer recommendations.

**Versatile Mounting Clips**

Encompass a tremendous range of beam spacing and flange widths.

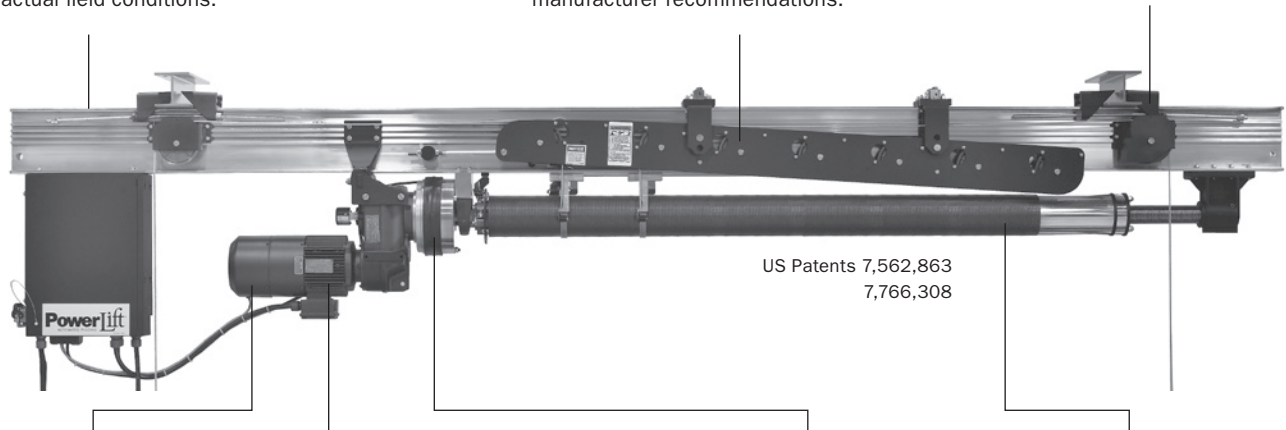
**Quiet, Secure Braking**

Engineered specifically for use in theatres.

**Quiet, Reliable Gearmotor**

Gearbox, motor, and primary brake are an integrated unit providing proven reliability. It's been our standard for 30 years—and for thousands of hoists! Iron case for vibration and noise control.

**SureBrake® II — Added Assurance and Protection**

The failsafe electric brake system monitors the speed of the drum, automatically stopping the hoist if it exceeds either the commanded speed or maximum speed.

**Compact Moving Drum**

Allows for a small, efficient hoist. Preloaded chase rollers ensure that cables stay in grooves.

**Affordable, Reliable Automated Rigging**

Automated rigging greatly enhances the impact of your productions with seamless scenery changes and dramatic movements. PowerLift hoists are in use in schools, universities, and professional theatres worldwide.

**Safety & Simplicity**

- Predictable, consistent scenery movements at every performance with SceneControl®, Altus™, and SureTarget™ consoles.
- Dual-brake system to ensure reliable stops and holds loads securely for long periods.
- No need to handle counterweight or climb to loading galleries.
- J.R. Clancy has built moving drum hoists for 50 years, resulting in compact hoists that free up backstage space.
- PowerLifts are ETL Listed.
- PowerLifts can be provided with optional load monitoring to stop movement in case of overload or underload, and to display the lifted load.

### Mounting

PowerLifts can be mounted vertically on the fly tower wall, minimizing space requirements. Horizontal mounting is also available. Access to the PowerLifts is required for mandatory OSHA maintenance and inspection.

### A Family of Hoists to Meet your Performance Requirements

The PowerLift family of hoists gives you the choices you need to meet your rigging requirements:

- **E-series Performance Hoists**

Five variable speed models offer combinations of speeds and lifting speeds that let you make subtle changes, or fast dramatic moves — and anything in between.

- **T-series Targeted Hoists**

A fixed speed hoist for your lighting and other utility sets, with four programmable stops for accurate, repeatable positioning.

### Modifications

We can provide double purchase PowerLifts for higher capacity and travel of up to 30' (9.15m). Single purchase PowerLifts with 8 lift lines and 49' (14.9m) of travel (with the same load capacity as the 7-line version) are also available.

